



HITS THE MARK: THE NEW BLACKBIRD

Trailing shoe technology
for the future from Vogelsang

VOGELSANG – LEADING IN TECHNOLOGY

NEW



VOGELSANG 15 M BLACKBIRD
WITH EXACUT ECQ

- ✓ functionality and quality of work
- ✓ handling, operation and maintenance

DLG Test Report 7030

VOGELSANG



A NEW DIMENSION IN PRECISION

The new BlackBird® from Vogelsang

As in every stage of the liquid manure distribution process, accuracy is the key to maximum efficiency. Better plant growth, less nutrient loss and lower environmental impact – everything depends on depositing liquid manure precisely and only where it can have an optimum effect, which is at the base of the plants. Everything about the Vogelsang BlackBird trailing shoe linkage is designed specifically to apply the liquid manure as precisely as possible at this point. Take a look for yourself!

The Vogelsang BlackBird offers many advantages, such as a low weight, active pressure for optimum deposition under the plant, a compact transport position, easy retrofitting and a passive oscillation compensator in the central frame of the linkage. We felt that these were fundamental requirements that any trailing shoe linkage should meet. But we have gone much further and given this trailing shoe linkage a few more critical features that open up a whole new dimension.

BlackBird® stands for greater precision

Using flow simulations, the Vogelsang product developers tested a range of different trailing shoe geometry options. Intensive studies of the flow rate and the flow characteristics of liquid manure led to totally new findings. This resulted in a new, beak-like, more elongated form, which levels out the acceleration of the liquid manure at the discharge. The outflow over the entire discharge length of the shoe is more controlled and more even, while deposition involves no unnecessary plant contamination. This results in unprecedented precision in the deposition of liquid manure directly on or in the ground.

BlackBird® stands for better distribution accuracy

The precision distributor is the heart of the BlackBird. It can achieve the best possible positioning in the linkage. Combined with Vogelsang's typical hose layout, this ensures outstanding distribution accuracy. In addition, there is no "V shape" when starting and the liquid manure is spread over the entire field with no overlaps.

BlackBird® stands for safe transport

Thanks to sophisticated vibration absorption, there is minimal movement of the leaf springs. This ensures the smoother transport of the linkage.

BlackBird® stands for longer service life

In addition to the minimized signs of wear on the shoe and the skid thanks to their special form, the new springs and supports provide support against excessive loads on the entire design as they reduce vibrations. This linkage is also the first to feature black hoses, which have even higher UV resistance.

BlackBird® stands for simple assembly and retrofitting

Because of its compact design and its center of gravity close to the tank, the new trailing shoe linkage can be retrofitted with no problems. Thanks to the numerous assembly options and integrated holding and security device, it is easier to attach to any barrel. At the same time, the linkage is also optimized for tankers with a larger tire diameter, thanks to the sophisticated frame guide.



The flow-optimized outlet is a unique feature of the BlackBird, and its design is based on flow simulation data.

The result: Optimal geometry ensures high-precision placement of the liquid manure across the entire outlet, resulting in an even narrower liquid manure strip.

The skid also features novel geometry. This ensures even better distribution of the contents and improved soil penetration. And thanks to a special additional edge, the wear on the skid does not affect the joint shape or the slot.



EASY FIT ON ANY TANK

BlackBird® trailing shoe linkage in working widths of 12, 15 and 18 meters

Nutrients only come at a cost. Ensure they are used wisely with the BlackBird, available in working widths of 12, 15 and 18 meters. This linkage excels thanks to its great precision, distribution accuracy and longer service life. Moreover, the BlackBird fits on any existing tanker. With its compact design and center of gravity close to the tank, the new trailing shoe linkage can be easily retrofitted. An integrated holding and security device, along with numerous mounting options, make mounting on the tanker especially easy. The new trailing shoe linkage from Vogelsang is also ideal for tankers with a larger tire diameter. An offset side arm allows for fender heights of up to 2 meters. As you can see, the BlackBird is the perfect solution when it comes to retrofitting.

Flow-optimized liquid manure discharge for high-precision deposition of liquid manure in a narrow strip

Technically modified, pretensioned leaf springs for greater stability in the linkage

Modified hose layout to prevent V shape when starting and ensure better distribution accuracy



Integrated holding and security device in boom for easier assembly

Specifications and characteristics

- Working width: 12 m, 15 m and 18 m
- Transport width: 2.95 m
- Hose spacing: 25 cm
- Direct attachment or 3/4 point lifting system
- Passive oscillation compensator in central frame
- Active pressure on all skids
- DropStop mechanism folds up the linkage to ensure less contamination on headlands, roads and agricultural tracks
- Part-width section cut-off: mechanical or hydraulic



Optimum positioning of precision distributors centrally in boom for improved distribution accuracy

Simple retrofitting on existing tankers



Sophisticated skid geometry for longer service life and better spreading

BlackBird® advantages at a glance

High precision and distribution accuracy

- Optimum positioning of precision distributors centrally in boom
- Sophisticated hose layout to prevent V shape when starting and avoid overlaps
- Flow-optimized liquid manure discharge for high-precision deposition of liquid manure in a narrow strip
- Sophisticated skid geometry for better distribution and more precise deposition of liquid manure

High stability

- Passive oscillation compensator in central frame
- End position cushioned hydraulic cylinders for minimum frame loads when folding
- Innovative stable leaf with vibration damping for safe road transport

Long service life

- Black hoses for greater UV resistance
- Sophisticated skid geometry

Easy assembly and retrofitting

- Integrated holding and security device in boom
- Fits on every existing tanker, as well as tankers with larger tire diameters

STAYS CONSISTENTLY ON THE GROUND

**BlackBird® trailing shoe
linkages up to 21 and 24 meters'
working width**

Uniquely adaptable

The BlackBird as you know it – and yet completely new, in working widths of 21 and 24 meters. The BlackBird's advantages, such as unbeatable precision and distribution accuracy, high stability, long service life and simple assembly, also come as standard with this variant. But we know that we can do even better! The adjustment of the linkage relative to the ground also decisively contributes to the optimal placement of liquid manure directly under the plant. Precise placement of the nutrients is only possible when liquid manure is continuously deposited close to the ground. Our idea: A completely novel cantilever that provides height adjustment and pendulum compensation. And it does this independently for each side arm!

This means you can practically drive through a valley, with an ascending surface to the left and right – the linkage adapts completely to the contour of the ground. The height of the side arm is automatically balanced and, at the same time, it also swings to compensate (see Fig. Ground hugging of the linkage). Optimal ground hugging is always

CANTILEVER FOR CONTINUOUS GROUND HUGGING

Separate riser for
each side arm

Separate pendulum compen-
sation for each side arm

Support wheels for height guidance
and control of the side arms

PROTOTYPE

with up to 24 meters'
working width

Tidy appearance, as all cables are
integrated directly in the cantilever



ensured. The liquid manure is therefore always deposited under the plant. This again emphasizes the image of the BlackBird – precision in a new dimension.

Specifications and characteristics

- Working width: 21 m and 24 m
- Transport width: 2.99 m
- Hose spacing: 25 cm
- Direct attachment or 4-point lifting system
- Ideal ground hugging thanks to central pendulum compensation and riser for each half the working width; independent compensation for each side
- Active pressure on all skids
- Manual partial width folding from 24 m to 21 m working width
- Hydraulic partial width folding from 21 m to 18 m working width
- DropStop mechanism folds up the linkage to ensure less contamination on headlands, roads and agricultural tracks
- Part width section cut-off: hydraulic
- Compact transport position by optional tilt of each side arm to the tanker by 5 degrees

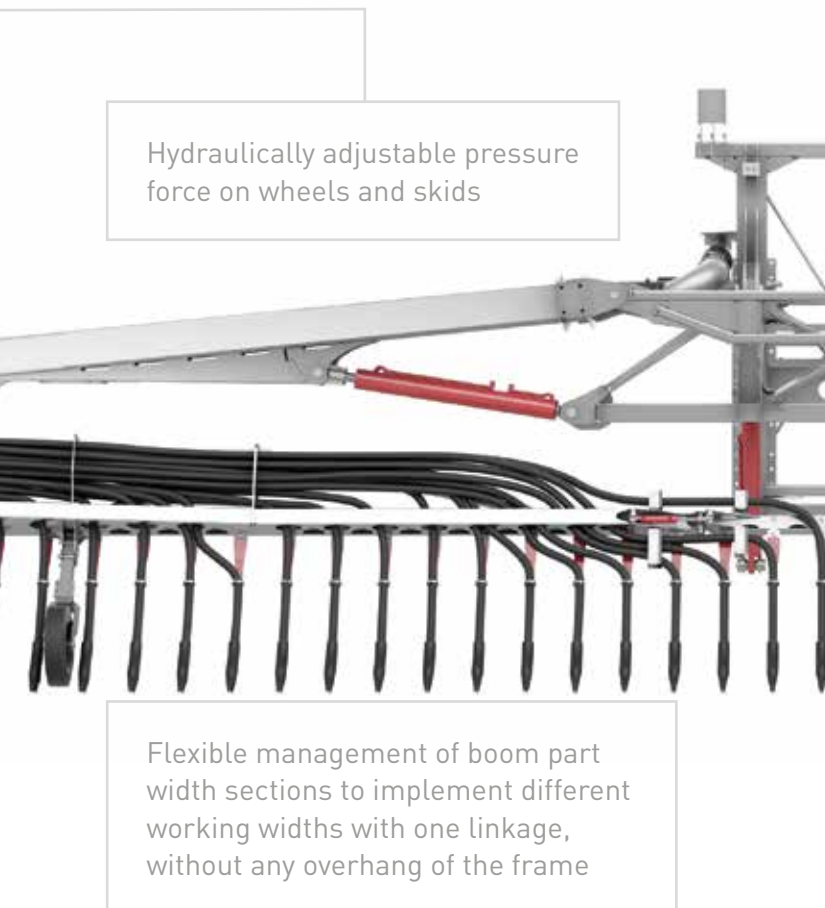

The cantilever's unique mode of action



Situation 1: The tanker is located in a depression. The surface rises to the right and to the left. Thanks to its cantilever, the BlackBird can also adapt effortlessly here: each side arm compensates independently for the respective lateral height increase.



Situation 2: The tanker is located at the edge of a slope. The left side arm is positioned sloping down while the right side is in the horizontal position. The integrated height and pendulum compensation of the left cantilever compensates for the unevenness. All skids therefore follow the soil contour throughout.

Ground hugging of the linkage

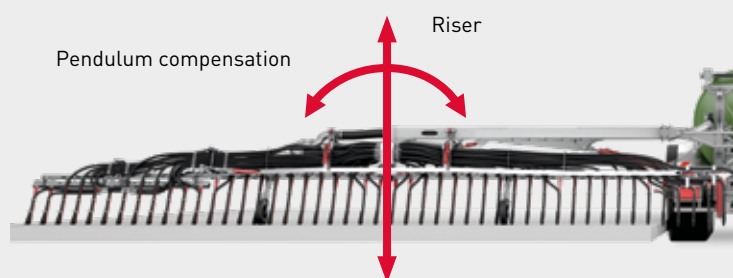

BlackBird® advantages at a glance

- Optimum, continuous ground hugging due to cantilever for optimum height and pendulum compensation
- Flexible management of boom part width sections for several working widths with only one linkage, without protrusion
- Clear optics of the entire linkage, since all cables are integrated in the cantilever

The basic advantages of the BlackBird are shown on the previous page.

What we offer

We provide solutions in the following sectors:
AGRICULTURAL TECHNOLOGY, BIOGAS,
INDUSTRY, TRANSPORTATION, WASTEWATER



Our broad range of products and services

- Consulting and service
- Data management and control technology
- Disintegration technology
- Individually tailored solutions for special applications
- Pumps and pump systems
- Solid matter feeders
- Solids reduction, separators and mixers
- Spreading technology
- Supply, disposal and cleaning

Copyright 2020 Vogelsang GmbH & Co. KG

Product availability, appearance, technical specifications and details are subject to continuous development. All information presented here is therefore subject to change. In selected countries, Vogelsang®, BioCrack®, BioCut®, BlackBird®, CC-Serie®, EnergyJet®, PreMix®, RotaCut®, XTill® and XRipper® are registered trademarks of Vogelsang GmbH & Co. KG, Essen/Oldb., Germany. All rights reserved, including the rights to all graphics and images.

BlackBird trailing shoe_EN_02207720_1000_MET0824 – Printed in Germany

Vogelsang GmbH & Co. KG
Holthoeye 10-14 | 49632 Essen/Oldb. | Germany
Phone: +49 5434 83-0 | Fax: +49 5434 83-10
germany@vogelsang.info

vogelsang.info

